

2016



Tahoe Police and Tahoe and Silverado Special Service Packages

chevrolet.com (U.S.)
chevrolet.gm.ca (Canada)
chevrolet.com.mx (Mexico)



Contents

Introduction	2
Keys, Doors, and Windows	5
Seats and Restraints	7
Instruments and Controls	18
Lighting	23
Driving and Operating	24
Vehicle Care	34
Technical Data	36
Special Equipment Options	38
Index	65

Introduction



The names, logos, emblems, slogans, vehicle model names, and vehicle body designs appearing in this manual including, but not limited to, GM, the GM logo, CHEVROLET, the CHEVROLET Emblem, SILVERADO, and TAHOE are trademarks and/or service marks of General Motors LLC, its subsidiaries, affiliates, or licensors.

For vehicles first sold in Canada, substitute the name "General Motors of Canada Limited" for Chevrolet Motor Division wherever it appears in this manual.

This manual describes features that may or may not be on the vehicle because of optional equipment that was not purchased on the vehicle, model variants, country specifications, features/applications that may not be available in your region, or changes subsequent to the printing of this owner manual.

Tahoe and Silverado Special Service Packages are not available in Mexico.

The Tahoe Police Package (SEO 9C1) is designed for police work up to and including high-speed emergency vehicle operations.

The Tahoe Special Service Package (SEO 5W4) and Silverado Special Service Package are neither designed nor intended for use in high-speed emergency vehicle operations.

Refer to the purchase documentation relating to your specific vehicle to confirm the features.

Keep this manual in the vehicle for quick reference.

Canadian Vehicle Owners

Propriétaires Canadiens

A French language manual can be obtained from your dealer, at www.helminc.com, or from:

On peut obtenir un exemplaire de ce guide en français auprès du concessionnaire ou à l'adresse suivant:

Helm, Incorporated
Attention: Customer Service
47911 Halyard Drive
Plymouth, MI 48170

Using this Supplement

This supplement contains information specific to the unique components of the vehicle. It does not explain everything you need to know about the vehicle. Read this supplement along with the owner manual to learn about the vehicle's features and controls.

Index

A good place to look for what you need is the Index in back of this supplement. It is an alphabetical list of what is in the supplement, and the page number where you will find it.

 **NOTES**

Keys, Doors, and Windows

Keys and Locks

Specific Cylinder Unit for Single Key - Random Code System 5

Keys and Locks

Specific Cylinder Unit for Single Key - Random Code System

If your vehicles are equipped with one of these options, the entire fleet of vehicle locks can be operated with one key.

- SEO 6E2 - Specific Fleet Key Code
- SEO 6E8 - Specific Fleet Key Code

Your vehicle will be equipped with a standard production random key code if one of the optional fleet codes was not ordered.

A maximum of eight keys may be learned for a vehicle immobilizer with a random key code. Vehicles with the specific fleet key option (SEO 6E2 or SEO 6E8) may have an unlimited number of keys learned using one of the original master keys.

For specific key code information, contact your dealer.

Vehicles will be equipped with a key cylinder in the ignition lock and the driver door only. Remote Keyless Entry (RKE) is a standard feature and operates all other doors and the rear liftgate, if equipped. Six additional RKE transmitters may have been ordered with your vehicle. Purchasing extra keys and RKE transmitters or programming are a customer's responsibility. See your dealer for additional information regarding availability of more keys and RKE units for your vehicle.

The RKE transmitter for your Tahoe Police and Special Service vehicle has the vehicle locator/panic alarm button disabled. The horn will not sound and the exterior lamps will not flash when the button is pressed.

The Silverado Special Service Package vehicle locator/panic alarm button can be turned off via the radio Vehicle Personalization Menu. See the Silverado owner manual.

6 Keys, Doors, and Windows

Remote Keyless Entry Transmitter Programming - SEO AMF - Fleet Package of Six Unprogrammed Remote Units (Tahoe Police and Tahoe Special Service Package Only)



Do not operate or program the transmitters in the vicinity of other vehicles that are in the keyless entry program mode. This prevents the programming of the transmitters to the incorrect vehicle.

When programming SEO AMF transmitters, the original two transmitters delivered with the vehicle must also be programmed at the same time or they will not function with the vehicle.

Up to eight transmitters may be programmed to the RKE on Tahoe Police and Tahoe Special Service Package equipped vehicles. The first four transmitters are given the position of #1-#4 in the RKE. Any further transmitters will also be assigned to position #4.

Verify that the proper transmitters are learned to the vehicle. Do not learn a transmitter with a remote start button to a vehicle that does not have remote start.

To access this DIC display, the vehicle must be in P (Park). To match an RKE transmitter to the vehicle:

1. Press the trip odometer reset stem until RELEARN REMOTE KEY displays.
2. Press and hold the trip reset stem for three seconds. The message REMOTE KEY LEARNING ACTIVE will display.
3. At the same time, press and hold  and  on the first transmitter for approximately 15 seconds. A beep will sound indicating the transmitter is matched to the vehicle.
4. Repeat Step 3 to match up to five more transmitters. A total of eight transmitters can be matched per vehicle.
5. To exit the programming mode, turn the ignition key to LOCK/OFF.

Seats and Restraints

Airbag System

Questions and Answers About
 Airbags and Specialty Law
 Enforcement Vehicles 7
 Customer-Installed
 Equipment 8
 Airbag Deployment
 Diagrams 10

Airbag System

Questions and Answers About Airbags and Specialty Law Enforcement Vehicles

Q: Can equipment such as radar devices, video cameras, and radio trees be mounted in a specialty vehicle equipped with a right front passenger frontal airbag?

A: Yes, but care must be taken to properly mount the equipment outside of the airbag “deployment zone.”

Q: What is the airbag “deployment zone”?

A: The term “deployment zone” describes the space an airbag takes up when fully inflated. Airbags need room to work properly, and anything in the “deployment zone” — such as improperly mounted equipment — can greatly affect the performance of the airbag.

 **Warning**

Airbags inflate with great force, faster than the blink of an eye. No objects, such as shotguns, should be placed over or near the airbag covers. Equipment mounted too close to an inflating airbag could prevent the airbag from operating properly to protect the occupants or could be forced into an occupant or break and become a dangerous projectile, causing severe injury or even death. To help prevent injury and to allow the airbag to perform as it was designed, do not mount equipment inside the airbag deployment zones.

8 Seats and Restraints

Q: How can I identify the airbag “deployment zone” in my vehicle?

A: See *Airbag Deployment Diagrams* ⇨ 10 for more information. The diagrams provide the approximate dimensions of the “deployment zones” for your specialty vehicle. Before doing any service work, including the installation of any equipment, consult the appropriate service manual.

Q: Is it possible to shield equipment so it does not interfere with airbag deployment?

A: While shielding may protect certain equipment from being damaged or dislodged, it may also negatively affect how an airbag inflates. Therefore, we cannot recommend the placement of any equipment in the deployment zone, even when shielding.

Q: Can the installation of push bumpers on the front end of the vehicle affect the deployment of the airbag?

A: It is not likely that installing push bumpers will affect sensing for the airbag as long as the vehicle structure itself is not modified. On pickup models, push bumper styles with vertical pushing members that are in fore-aft alignment with the front airbag sensors are not recommended. GM is not aware of any adverse defects from the many push bumpers that have been installed on current model GM police vehicles with airbags.

See “Adding Equipment to the Airbag-Equipped Vehicle” in the owner manual for more information.

Customer-Installed Equipment

Before installing equipment, read the following.

Warning

Do not install equipment in the inflation path of any airbag. The equipment may interfere with the deployment of the airbag, may damage the airbag, or otherwise be damaged or forced into an occupant, all of which may cause severe injury or even death.

Do not attach anything to the steering wheel hub or mount any equipment within the deployment zone for the driver airbag.

Do not mount equipment on the passenger side of the instrument panel top pad deployment zone. Equipment should not be mounted on or around the passenger airbag opening because of a deploying airbag.

(Continued)

Warning (Continued)

To allow the airbag to perform as it was designed, do not mount equipment inside the airbag deployment zone.

Do not use seat accessories that block the inflation path of the driver or passenger seat-mounted side impact airbag or install equipment in the seat-mounted side impact airbag deployment zones.

Do not mount a security barrier such that the ends of the barrier or brackets are within the roof-rail airbag deployment zones.

Avoid installing wiring for roof-rail emergency lighting or radio antennas that may restrict the proper deployment of the roof-rail airbags.

Do not use seat accessories, console accessories, or other accessories that block the

(Continued)

Warning (Continued)

inflation path of the driver seat front center airbag (if equipped). Do not remove the front center console to install a police package center console, or otherwise install equipment or mount equipment between or just behind the front bucket seats on vehicles equipped with the driver seat front center airbag.

Caution

GM approved service procedures must be followed to remove and reinstall the instrument panel to the pad to ensure proper airbag deployment.

Caution

The police vehicle has a rollover sensor mounted on the centerline of the vehicle between the driver and front outboard passenger positions. If the vehicle has individual front seats, the rollover sensor will be exposed. Do not mount equipment within 25 mm (1 in) of the rollover sensor. This may affect the performance of multiple restraint systems.

Airbag Deployment Diagrams

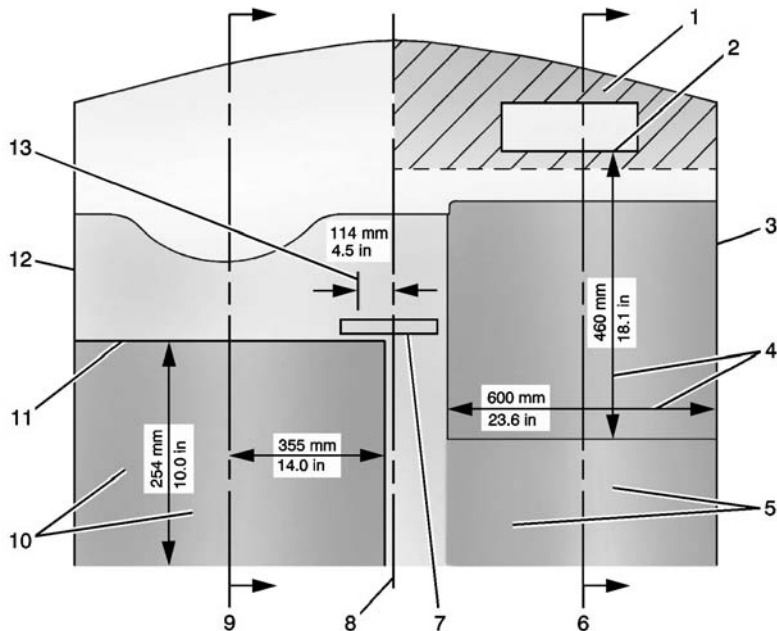

Instrument Panel Top View – Approximate Frontal Airbag Deployment Zones (Tahoe and Silverado)

1. Passenger Side Instrument Panel Top Surface Zone
2. Passenger Frontal Airbag Module Trim Panel – Rear Edge
3. Passenger Side Door
4. Approximate Dimensions of Inflated Airbag
5. Passenger Frontal Airbag Deployment Zone
6. Passenger Centerline
7. Inside Rearview Mirror
8. Vehicle Centerline
9. Driver Centerline
10. Driver Frontal Airbag Deployment Zone
11. Front of Steering Wheel (See also “Side View of Driver Frontal Airbag Deployment Zone” Following)
12. Driver Side Door
13. Shift Selector Arc

See *Customer-Installed Equipment* ⇨ 8.

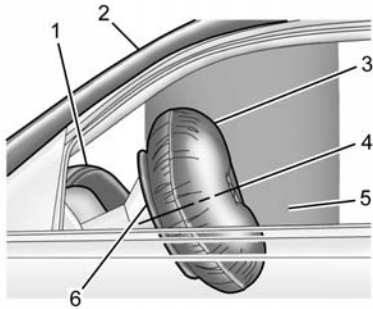

Side View of Driver Frontal Airbag Deployment Zone

1. Top of Instrument Panel
2. Top Edge of Windshield
3. Inflated Airbag – Steering Wheel
4. Centerline of Steering Column at Mid-Tilt
5. Driver Frontal Airbag Deployment Zone
6. Front of Steering Wheel

See *Customer-Installed Equipment* ⇨ 8.

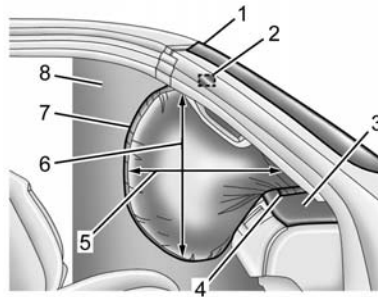

Side View of Passenger Frontal Airbag Deployment Zone

1. Top Edge of Windshield
2. Inside Rearview Mirror
3. Instrument Panel Top Surface Zone
4. Passenger Frontal Airbag Module Trim Panel – Rear Edge
5. Inflated Airbag – Horizontal Dimension (Approximately 460 mm (18.1 in))

6. Inflated Airbag – Vertical Dimension (from Top of Occupant's Lap to Headliner)
7. Inflated Airbag – Instrument Panel
8. Passenger Frontal Airbag Deployment Zone

See *Customer-Installed Equipment* ⇨ 8.

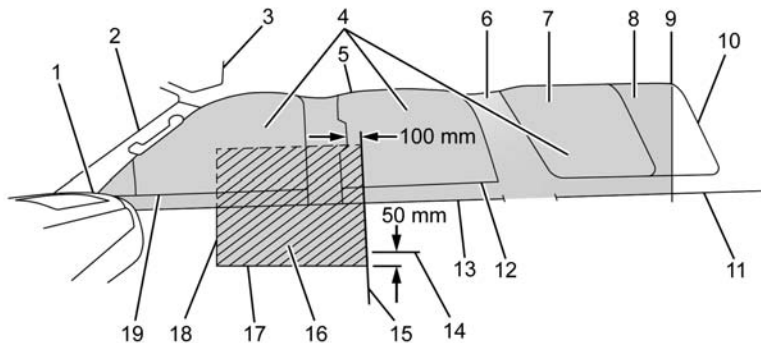

Roof-rail and Seat-mounted Side Impact Airbag Deployment Zones – Passenger Side Shown, Driver Side Similar – Tahoe

1. Front of Deployment Zone at Bottom of Windshield Pillar Trim
2. A-Pillar Trim with Grab Handle (Passenger Side)
3. Sun Visor
4. Deployment Zone – Seat Rows 1 and 2 and Cargo Area

5. Top of Deployment Zone – Along Roof-rail at Edge of Headliner
6. C-Pillar Upper Trim
7. Rear Quarter Window
8. D-Pillar Upper Trim

9. Rear of Cargo Area Zone at Back Corner of Headliner
10. Rear of Vehicle at Liftgate Opening
11. Bottom of Cargo Area Zone at Rear Side Trim Cupholders
12. Top Edge of Rear Door Trim
13. Bottom of Deployment Zone at Top of Side Door Armrests
14. Top Surface of Front Seat Cushion (with Seat Fully Lowered)
15. Seat-Mounted Side Impact Airbag Deployment Zone (100 mm (3.9 in) to Rearward of Back Edge of B-Pillar Trim Grab Handle)
16. Lower Part of Front Seat Deployment Zone (with Seat Fully Lowered)
17. Bottom of Seat-Mounted Side Impact Airbag Zone (50 mm (2.0 in) Below Top of Seat Cushion with Seat Fully Lowered)

18. Rear of Front Door Trim
Armrest Handle

19. Top Edge of Front Door Trim

The roof-rail airbag deploys in the cargo area. Third-row seating is not available on the police package (RPO 9C1) or the special service package (RPO 5W4).

See *Customer-Installed Equipment* ⇨ 8.

14 Seats and Restraints

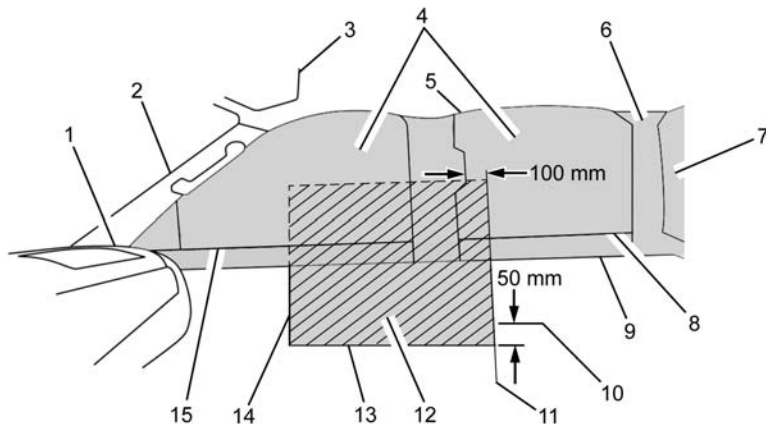

Roof-rail and Seat-mounted Side Impact Airbag Deployment Zones – Passenger Side Shown, Driver Side Similar – Silverado

1. Front of Deployment Zone at Bottom of Windshield Pillar Trim
2. A-Pillar Trim with Grab Handle (Passenger Side)
3. Sun Visor
4. Deployment Zone – Seat Rows 1 and 2 and Cargo Area

5. Top of Deployment Zone – Along Roof-rail at Edge of Headliner
6. C-Pillar Upper Trim
7. Rear Window
8. Top Edge of Rear Door Trim

9. Bottom of Deployment Zone at Top of Side Door Armrests
10. Top Surface of Front Seat Cushion (with Seat Fully Lowered)
11. Seat-Mounted Side Impact Airbag Deployment Zone (100 mm (3.9 in) to Rearward of Back Edge of B-Pillar Trim Grab Handle)
12. Lower Part of Front Seat Deployment Zone (with Seat Fully Lowered)
13. Bottom of Seat-Mounted Side Impact Airbag Zone (50 mm (2.0 in) Below Top of Seat Cushion with Seat Fully Lowered)
14. Rear of Front Door Trim Armrest Handle
15. Top Edge of Front Door Trim

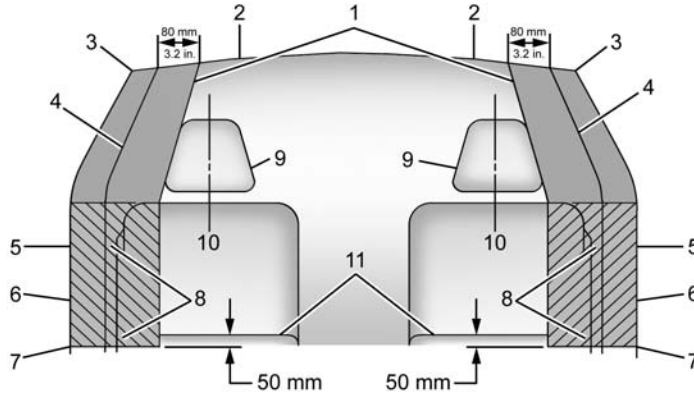

Roof-rail and Seat-mounted Side Impact Airbag Driver and Passenger Deployment Zones – View from Rear of Vehicle (Tahoe and Silverado)

- | | |
|--|--|
| <ul style="list-style-type: none"> 1. Roof-rail Airbag Deployment Zone 2. Underside of Headliner 3. Edge of Headliner 4. Inner Center and Rear Pillar Trim 5. Inner Front and Rear Door | <ul style="list-style-type: none"> 6. Side Door Upper Armrests and Rear Quarter Trim Armrests 7. Seat-Mounted Side Impact Airbag Deployment Zone (50 mm (2.0 in) Below Top Surface of Outboard Front Seat Cushion with Seat Fully Lowered) |
|--|--|

- 8. Front Seatback Side Deployment Zone
- 9. Front Seat Head Restraint
- 10. Seat Centerline
- 11. Top of Seat Cushion

The driver and passenger seat-mounted side impact airbag deployment zones move up, down, fore, aft, as the seat is adjusted by the occupant. The deployment zones also move as the seatback is reclined and raised.

See *Customer-Installed Equipment* ⇨ 8.

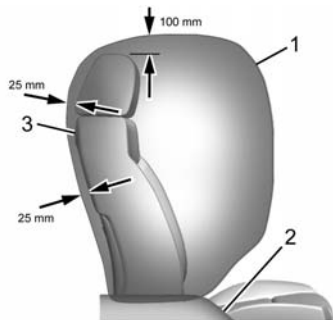

Optional Driver Seatback Front Center Airbag (RPO AYQ and D07)
– View from Passenger Side –
Tahoe

1. Driver Seatback Front Center Airbag
2. Front Center Console
3. Driver Seat and Head Restraint

The driver and passenger seat-mounted side impact airbag deployment zones move up, down, fore, aft, as the seat is adjusted by the occupant. The deployment zones also move as the seatback is reclined and raised.

The driver seatback front center airbag (RPO AYQ) requires front bucket seats (RPO A95) and the front center console (RPO D07). Do not remove the front center console to install customer equipment or install customer equipment between the front bucket seats on or around the center console. The equipment may interfere with the deployment of the driver seatback front center airbag.

See *Customer-Installed Equipment* ⇨ 8.

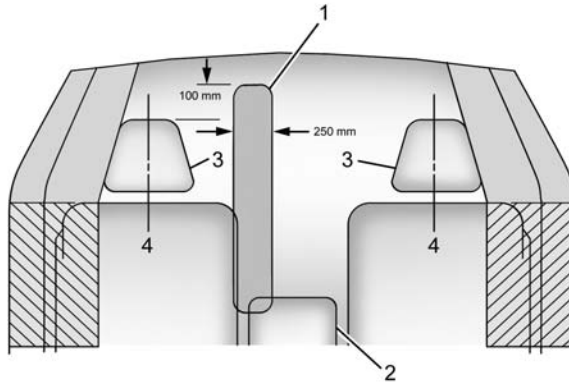

Optional Driver Seatback Front Center Airbag Deployment Zone (RPO AYQ and D07) – View from Rear Cargo Area – Tahoe

- 1. Driver Seatback Front Center Airbag (RPO AYQ)
- 2. Front Center Console (RPO D07)
- 3. Front Seat Head Restraint
- 4. Seat Centerline

The driver and passenger seat-mounted side impact airbag deployment zones move up, down, fore, aft, as the seat is adjusted by the occupant. The deployment zones also move as the seatback is reclined and raised.

The driver seatback front center airbag (RPO AYQ) requires front bucket seats (RPO A95) and the front center console (RPO D07). Do not remove the front center console to install customer equipment or install customer equipment between the front bucket seats on or around the center console. The equipment may interfere with the deployment of the driver seatback front center airbag.

See *Customer-Installed Equipment* ⇨ 8.

Instruments and Controls

Warning Lights, Gauges, and Indicators

Instrument Cluster (Tahoe)	19
Instrument Cluster (Silverado)	21
Speedometer	22

Information Displays

Driver Information Center (DIC)	22
--	----

Warning Lights, Gauges, and Indicators

Instrument Cluster (Tahoe)

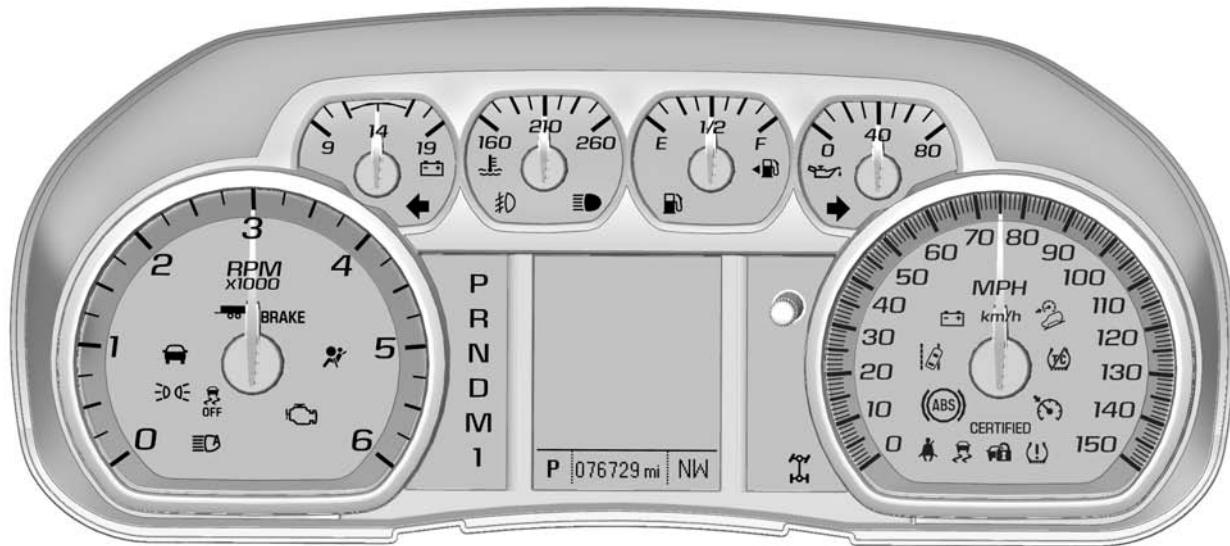

Tahoe Police Package (SEO 9C1) Cluster (English Shown, Metric Similar)

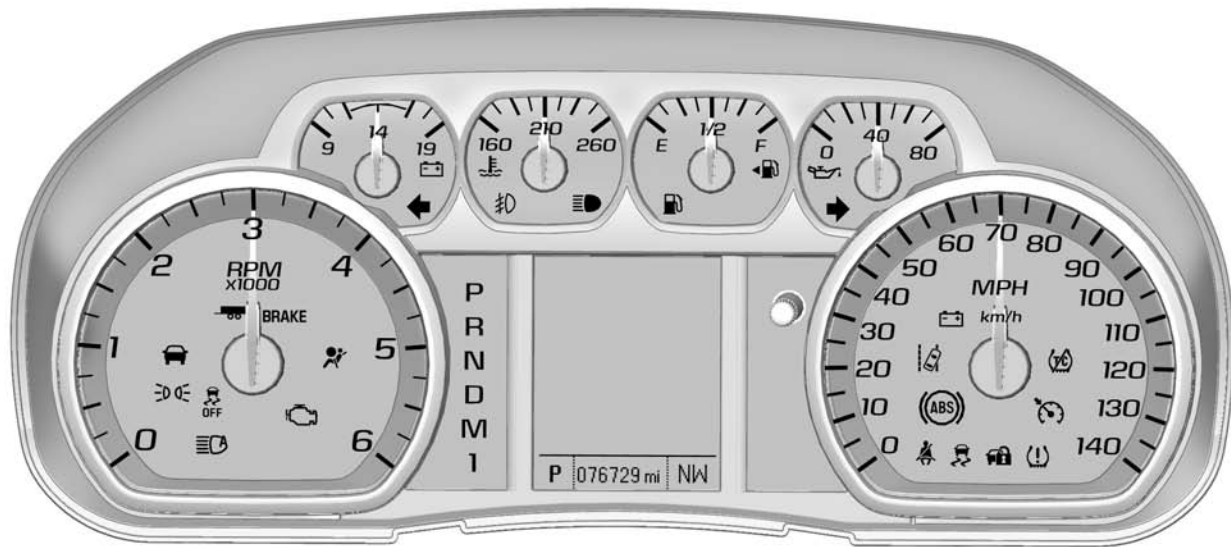

Tahoe Special Service Package (SEO 5W4) Cluster (English Shown, Metric Similar)

Instrument Cluster (Silverado)

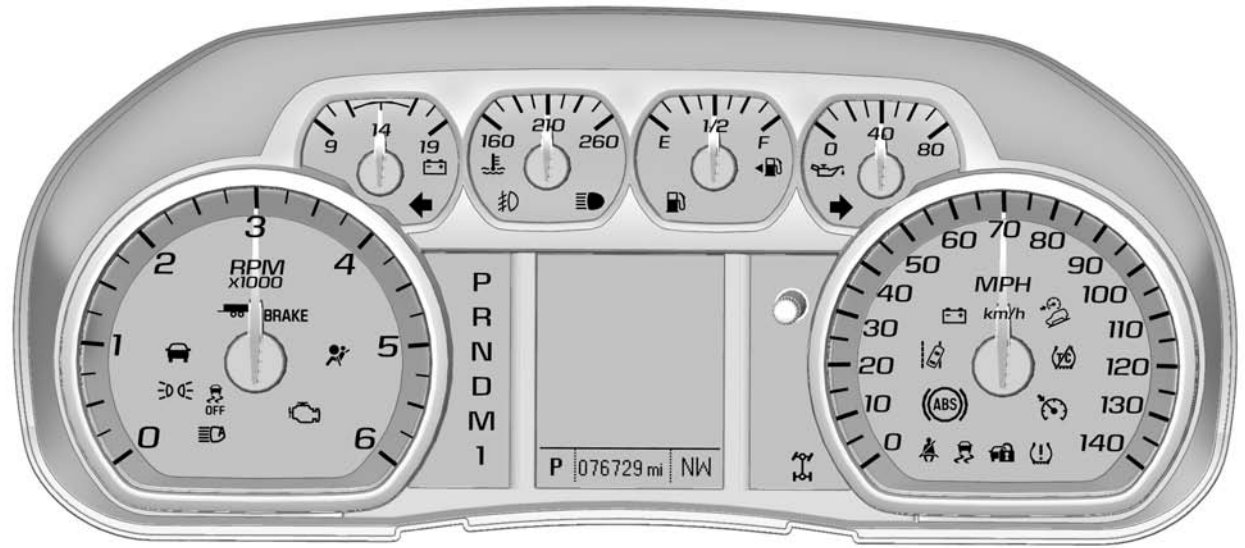

Speedometer

The speedometer shows the vehicle's speed in kilometers per hour (km/h) or miles per hour (mph).

The speedometer for the Tahoe Police Package (SEO 9C1) displays a maximum vehicle speed of 240 km/h (150 mph). The speedometer for the Tahoe Special Service Package (SEO 5W4) and the Silverado Special Service Package displays a maximum vehicle speed of 200 km/h (140 mph). The Tahoe Special Service Package and the Silverado Special Service Package are neither designed nor intended for use in high-speed emergency vehicle operations.

Speedometer Certification

Specifications at temperatures of -23 to 49 °C (-10 to 120 °F).

Inaccuracies due to vehicle speed sensing are included. This vehicle is equipped with an electronically controlled speedometer which is designed to be accurate +/- 3 km/h (+/- 2 mph) through its range of function.

Information Displays

Driver Information Center (DIC)

The Tahoe Police Package and Special Service Package do not have DIC buttons. You can turn off or acknowledge the available DIC messages by using the trip odometer reset stem on the instrument cluster.

The DIC will display engine running hours.

Relearn Remote Key

The Tahoe Police and Special Service Packages have an additional item in the DIC menu for re-learn remote key. The Silverado Special Service Package key must be re-learned by a dealer. See "Remote Keyless Entry Transmitter Programming" in Section 2 of this manual.

See the owner manual for additional information on the DIC.

Lighting

Exterior Lighting

Exterior Lamp Controls 23

Exterior Lighting

Exterior Lamp Controls

The following exterior lighting features apply to vehicles first sold in the United States.

The vehicle has Daytime Running Lamps (DRL) and an Automatic Headlamp System (AHS). The DRL and AHS can be turned off with the headlamp switch when the transmission is in P (Park) and the engine is at idle. If the engine is not turned off, the DRL and AHS will remain off when the transmission is placed in gear. The vehicle may be driven with the lamps off for one ignition cycle.

The vehicle may have been built with Special Equipment Option (SEO) 9G8, DRL and AHS DISABLE. This feature turns off DRL and AHS and requires manual control of the exterior lighting. See your dealer to restore the DRL and AHS to normal operation.

For vehicles first sold in Canada, the DRL and AHS can be turned off if the transmission is in P (Park). See “Daytime Running Lamps (DRL)” in the owner manual.

Special Features

The following standard features are disabled in the Tahoe Police Package and Special Service Package:

- Entry Lighting and Exit Lighting
- Remote Keyless Entry Feedback (Horn Beep) and (Lamps Flash)

Automatic Door Locking is standard. If you need it disabled, see your dealer. The Silverado Special Service Package door locking and other features can be disabled via the radio. See “Vehicle Personalization” in the owner manual.

The Tahoe Police and Special Service vehicles may have SEO UTQ, which disables the theft-deterrent system visual and audible warning. See “Vehicle Security” in the owner manual.

Driving and Operating

Driving Information

Vehicle Load Limits 24

Starting and Operating

Fast Idle System 27

Fuel

E85 or FlexFuel 28

Filling the Tank 28

Towing

Trailer Towing 29

Driving Information

Vehicle Load Limits

The information in this section of the supplement is for those who intend to install additional equipment to the police vehicle after it has left the factory, and for those who will be driving and loading the vehicle with passengers and/or cargo.

Two labels on your vehicle show how much weight it was designed to carry, the Tire and Loading Information label and the Certification/Tire label. These labels are attached to your vehicle and give you the maximum load capacity, the Gross Vehicle Weight Rating (GVWR) and the Gross Axle Weight Rating (GAWR) for your vehicle. See "Vehicle Load Limits" in the owner manual for additional loading information.

The following guidelines can help you with proper loading and load distribution when installing additional equipment on the Tahoe Police Package and Tahoe and Silverado Special Service Packages.

Warning

Do not load the vehicle any heavier than the Gross Vehicle Weight Rating (GVWR), or either the maximum front or rear Gross Axle Weight Rating (GAWR). This can cause systems to break and change the way the vehicle handles. This could cause loss of control and a crash. Overloading can also reduce stopping distance, damage the tires, and shorten the life of the vehicle.

Adding Equipment to Your Vehicle

Before adding accessories or equipment to your police vehicle, there are some things you need to know:

- The police vehicle's maximum capacity weight.
- The weight of your police vehicle, including a full tank of fuel but without a driver and passengers.
- The weight of items you plan on adding to your police vehicle, like roof mounted light bar(s), push bumpers, security barrier(s), rear storage organizer, highway flares, fire extinguishers, weapons, ammunition, radios, and video equipment.
- The weight and number of passengers you intend to carry in your vehicle.
- The total weight of any additional cargo you intend to carry in your vehicle.

When planning your vehicle equipment installation, remember not to exceed the Gross Vehicle Weight Rating (GVWR) or the Gross Axle Weight Rating (GAWR) of the front or rear axles. To keep the available load weight less than the vehicle capacity weight, you may need to limit the number of passengers you carry in your vehicle or change your choice of additional equipment.

Center of Gravity (CG)

A vehicle's center of gravity is an imaginary location inside the vehicle and is a balance point for the vehicle mass as it moves down the road. The police vehicle's center of gravity, before you add a load and passengers, is approximately midway between the center of the axles, up from the ground to just below the front window, and between the driver and passenger.

Equipment location and weight on the vehicle's center of gravity is important to keep in mind when planning an installation. Heavy equipment should be positioned as

low and as far forward in the rear load compartment as possible. Try to mount the equipment below the bottom of the side windows. Refer to the Loading Zone chart and diagram to help with your installation plan.

A procedure to make the necessary measurements and formulas to calculate the vehicle longitudinal, lateral, and vertical position of the center of gravity can be found in the GM Coachbuilders Manual. Equipment required to conduct the measurements for calculating the center of gravity are:

- Weight scales of sufficient capacity to measure the vehicle weight at each wheel.
- A post-type hoist or other means to safely elevate the front of the vehicle to at least an angle of 20 degrees above horizontal.

See your GM dealer to get more information about this coachbuilder procedure.

Keeping the center of gravity midway between the axles is also important to provide proper braking performance. About half the total vehicle weight on each axle is recommended.

Weigh your vehicle after the additional equipment has been installed to determine the actual weight of your vehicle. Weigh the vehicle with a full tank of fuel and without passengers. You may need to put a limit on how many people or other equipment you can carry inside your vehicle after the additional equipment has been installed.

Loading Zones — Tahoe Only

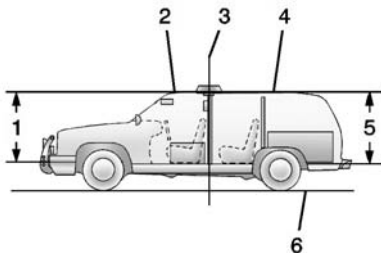

1. Front Floor to Roof Zone Area
2. Front Roof Zone Area
3. Back of Front Door
4. Rear Roof Zone Area
5. Rear Floor to Roof Zone Area
6. Ground

Loading Zone Weight Chart			
Values shown are for the vehicle at maximum curb weight and six passengers.			
Loading Zones	Front Axle Weight	Rear Axle Weight	Total
Roof	11 kg (25 lb)	15 kg (34 lb)	26 kg (59 lb)
Floor to Roof	41 kg (91 lb)	163 kg (360 lb)	204 kg (451 lb)
Total	52 kg (116 lb)	178 kg (394 lb)	230 kg (510 lb)

Using heavier suspension components to get added durability might not change your weight ratings. Ask your dealer to help you load your vehicle the right way.

See the Silverado owner manual for proper loading information for the Silverado Police Package vehicle.

Starting and Operating

Fast Idle System

While parked with the engine idling for an extended period, turn off the following factory equipment if emergency lighting and communication equipment are operating:

- Air Conditioner
- Fan
- Rear Window Defogger
- Factory Audio System

See “Running the Vehicle While Parked” in the owner manual.

Engine Idle Speed - Alternator Output

Normal idle speed for the engine is set for 600 rpm. To increase alternator output while the transmission remains in P (Park) or N (Neutral), and the electrical load on the alternator is large enough, the engine idle speed can rise to as high as 800 to 1000 rpm.

Fuel

E85 or FlexFuel

Fleet Fuel Use

For fleets that use only E85 or FlexFuel, occasionally filling the tank with gasoline will help keep the fuel system clean.

Filling the Tank

Warning

Fuel vapors and fuel fires burn violently and can cause injury or death.

- To help avoid injuries to you and others, read and follow all the instructions on the fuel pump island.
- Turn off the engine when refueling.
- Keep sparks, flames, and smoking materials away from fuel.

(Continued)

Warning (Continued)

- Do not leave the fuel pump unattended.
- Do not use a cell phone while refueling.
- Do not reenter the vehicle while pumping fuel.
- Keep children away from the fuel pump and never let children pump fuel.
- Fuel can spray out if the fuel cap is opened too quickly. This spray can happen if the tank is nearly full, and is more likely in hot weather. Open the fuel cap slowly and wait for any hiss noise to stop then unscrew the cap all the way.

The fuel cap is behind a hinged fuel door on the driver side of the vehicle. If the vehicle has E85 fuel capability, the fuel cap will be yellow and state that E85 or gasoline can be used. See *E85 or FlexFuel* ⇨ 28.

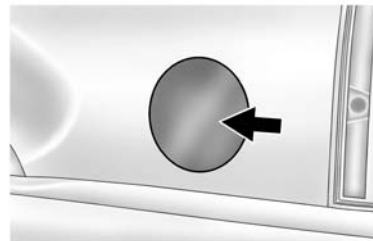

To open the fuel door, push and release the rearward center edge of the door.

To remove the fuel cap, turn it slowly counterclockwise. While refueling, hang the tethered fuel cap from the hook on the fuel door.

Be careful not to spill fuel. Do not top off or overfill the tank. Wait a few seconds after you have finished pumping before removing the nozzle. Clean fuel from painted surfaces as soon as possible. See “Exterior Care” in the owner manual.

When replacing the fuel cap, turn the fuel cap clockwise until it clicks. It will require more effort to turn the

fuel cap on the last turn as you tighten it. Make sure the cap is fully installed. The diagnostic system can determine if the fuel cap has been left off or improperly installed. This would allow fuel to evaporate into the atmosphere. See “Malfunction Indicator Lamp” in the owner manual.

The TIGHTEN GAS CAP message displays if the fuel cap is not properly installed.

Warning

If a fire starts while you are refueling, do not remove the nozzle. Shut off the flow of fuel by shutting off the pump or by notifying the station attendant. Leave the area immediately.

Caution

If a new fuel cap is needed, be sure to get the right type of cap from your dealer. The wrong type of fuel cap may not fit properly, may cause the malfunction indicator lamp to light, and could damage the fuel tank and emissions system. See “Malfunction Indicator Lamp” in the owner manual.

Towing

Trailer Towing

For more information, see “Trailer Towing” in the owner manual.

Weight of the Trailer

How heavy can a trailer safely be?

It depends on how the rig is used. For example, speed, altitude, road grades, outside temperature and how much the vehicle is used to pull a trailer are all important. It can depend on any special equipment on the vehicle, and the amount of tongue weight the vehicle can carry.

Maximum trailer weight is calculated assuming only the driver is in the tow vehicle and it has all the required trailering equipment. The weight of additional optional equipment, passengers, and cargo in the tow vehicle must be subtracted from the maximum trailer weight.

For Tahoe Police and Special Service Package vehicles, the Trailer Weight Rating (TWR) is calculated assuming the tow vehicle has only the driver and all required trailering equipment. Weight of additional optional equipment, passengers, and cargo in the tow vehicle must be subtracted from the trailer weight rating.

For Silverado Special Service Package vehicles, the Trailer weight rating (TWR) is calculated assuming the tow vehicle has the driver, a front seat passenger, and all required trailering equipment. Weight of additional optional equipment, passengers, and cargo in the tow vehicle must be subtracted from the trailer weight rating.

Use the following chart to determine how much the vehicle can weigh, based upon the vehicle model and options.

2016 Tahoe Police Package

Tahoe Police Package			
Vehicle	Axle Ratio	Maximum Trailer Weight (c)	GCWR (a)
2WD	3.08	1 814 kg (4,000 lb)	4 264 kg (9,400 lb)
4WD	3.08	1 814 kg (4,000 lb)	4 355 kg (9,600 lb)

*The Gross Combination Weight Rating (GCWR) is the total allowable weight of the completely loaded vehicle and trailer including any passengers, cargo, equipment, and conversions. The GCWR for the vehicle should not be exceeded.

2016 Tahoe Special Service Package

Tahoe Special Service Package			
Vehicle	Axle Ratio	Maximum Trailer Weight (c)	GCWR (a)
4WD	3.08	2 903 kg (6,400 lb)	5 443 kg (12,000 lb)
4WD w/18" Wheels (NHT)	3.42	8 400 kg (3,810 lb)	6 350 kg (14,000 lb)

*The Gross Combination Weight Rating (GCWR) is the total allowable weight of the completely loaded vehicle and trailer including any passengers, cargo, equipment, and conversions. The GCWR for the vehicle should not be exceeded.

2016 Silverado Special Service

Silverado Special Service Package – SAE J2807 Compliant			
Vehicle	Axle Ratio	Maximum Trailer Weight (c)	GCWR (a)
1500 Series 2WD Regular Cab Standard Box			
5.3LV8	3.08	2 858 kg (6,300 lb)	5 443 kg (12,000 lb)
5.3LV8	3.42	4 213 kg (9,300 lb)	6 804 kg (15,000 lb)
5.3LV8	3.73	4 990 kg (11,000 lb)	7 575 kg (16,700 lb)
1500 Series 2WD Crew Cab Short Box (b)			
5.3LV8	3.08	2 903 kg (6,400 lb)	5 443 kg (12,000 lb)
5.3LV8	3.42	4 264 kg (9,400 lb)	6 804 kg (15,000 lb)
5.3LV8	3.73	5 035 kg (11,100 lb)	7 575 kg (16,700 lb)
1500 Series 4WD Regular Cab Standard Box			
5.3LV8	3.08	2 767 kg (6,100 lb)	5 443 kg (12,000 lb)
5.3LV8	3.42	4 128 kg (9,100 lb)	6 804 kg (15,000 lb)
5.3LV8	3.73	4 899 kg (10,800 lb)	7 575 kg (16,700 lb)

2016 Silverado Special Service (cont'd)

Silverado Special Service Package – SAE J2807 Compliant			
Vehicle	Axle Ratio	Maximum Trailer Weight (c)	GCWR (a)
1500 Series 4WD Crew Cab Short Box (b)			
5.3L V8	3.08	2 767 kg (6,100 lb)	5 443 kg (12,000 lb)
5.3L V8	3.42	4 128 kg (9,100 lb)	6 804 kg (15,000 lb)
5.3L V8	3.73	4 899 kg (10,800 lb)	7 575 kg (16,700 lb)
<p>(a) The Gross Combination Weight Rating (GCWR) is the total allowable weight of the completely loaded vehicle and trailer including any passengers, cargo, equipment, and conversions. The GCWR for the vehicle should not be exceeded.</p> <p>(b) This model is neither designed nor intended to tow fifth-wheel or gooseneck trailers.</p> <p>(c) For chassis cab and pickup box delete vehicles, choose an appropriate hitch and load the truck and trailer within the limits of GCWR, GVWR, and RGAWR.</p>			

Vehicle Care

Wheels and Tires

Tires	34
Tire Pressure Monitor System	34

Appearance Care

Floor Mats	35
------------------	----

Wheels and Tires

Tires

Tahoe Police and Special Service Packages

Refer to the Tire and Loading Information label, on the driver B-pillar, for information regarding tire sizes, speed ratings, and recommended tire inflation pressures. See "Tire and Loading Information Label" under "Vehicle Load Limits" in the owner manual. The Tahoe and Silverado Special Service Packages are not designed nor intended for use in high-speed emergency vehicle operations.

Wheels

If the vehicle has metal hub caps, they are bolted to the wheels and do not require removal when rotating or removing the wheels. Loosening

or tightening the decorative wheel attachment nuts can be done with the hub caps in place.

Tire Pressure Monitor System

The Tahoe Police and Special Service Packages may have a Tire Pressure Monitor System (TPMS). Sensors are mounted on each tire and wheel assembly. Only the Tahoe Police Package (SEO 9C1) has a TPM sensor in the full-size spare tire and wheel assembly. The TPM system will not monitor or display the spare tire's air pressure until it is installed onto one of the four tire/wheel positions on your vehicle.

The Silverado Special Service vehicle may have a full-size spare tire and TPM sensor, Option OOA.

Once installed, the spare tire's sensor code must be matched to its new tire/wheel position on your vehicle. See "Tire Pressure Monitor System" in the owner manual for information about the TPM system.

Appearance Care

Floor Mats

 **Warning**

If a floor mat is the wrong size or is not properly installed, it can interfere with the pedals. Interference with the pedals can cause unintended acceleration and/or increased stopping distance which can cause a crash and injury. Make sure the floor mat does not interfere with the pedals.

Use the following guidelines for proper floor mat usage.

- The original equipment floor mats were designed for the vehicle. If the floor mats need replacing, it is recommended that GM certified floor mats be purchased. Non-GM floor mats may not fit properly and may

interfere with the pedals. Always check that the floor mats do not interfere with the pedals.

- Do not use a floor mat if the vehicle is not equipped with a floor mat retainer on the driver side floor.
- Use the floor mat with the correct side up. Do not turn it over.
- Do not place anything on top of the driver side floor mat.
- Use only a single floor mat on the driver side.
- Do not place one floor mat on top of another.

See the owner manual for more floor mat information.

Technical Data

Vehicle Data

Capacities and
Specifications 37

Vehicle Data

Capacities and Specifications

Capacities

Application	Capacities	
	Metric	English
Cooling System	17.1 L	18.1 qt

Special Equipment Options

SEO Standard Options

SEO Standard Options - Police Package and Special Service Package	39
Wiring Provisions for 12-Volt Battery Power Supply (Tahoe)	40
Auxiliary Battery Power Junction Blocks	44
Radio Suppression Grounding Straps	45

SEO Available Options

Auxiliary Dome Lamp - SEO 6C7	45
Exterior Lamp Emergency Flashing System - SEO 6J7 (Tahoe)	45
Exterior Lamp Emergency Flashing System - SEO 6J7 (Silverado)	48
Rear Windows Inoperative - SEO 6N5 (Tahoe)	50
Inoperative Rear Door Locks and Handles - SEO 6N6 (Tahoe)	50
Spotlamp - SEO 7X6	51
Spotlamps - SEO 7X7	54
Wiring Provisions for Vehicle Grille Lamps and Speaker/ Siren - SEO 6J3	54

Trunk Ground Stud - SEO UT7 (Tahoe)	57
Wiring Provisions for 12-Volt Battery Power Supply - SEO 9L7 (Silverado)	57
Wiring Provisions for Horn/Siren Circuit - SEO 6J4	61
Wiring Provisions Front Speakers - SEO WX7 (Tahoe)	63

SEO Standard Options

SEO Standard Options - Police Package and Special Service Package

Caution

GM cannot be responsible for any changes made to the vehicle. Have all electrical and body modifications performed by experienced technicians.

- Be sure that any modified or added wiring will work properly with your vehicle's wiring system.
- See that all wiring is properly protected by fuses, and not causing an overload to connectors and components.

(Continued)

Caution (Continued)

- Do not route wiring in areas of the vehicle where temperatures can be high or where wiring may be cut, pinched, or rubbed.
- See that all added wiring is of the same or smaller gauge than the wire it is being attached to for proper fuse protection.
- Be sure that all holes drilled in the body are properly sealed and corrosion protected. See that the vehicle's wiring harnesses, piping, and other components have not been displaced or damaged during customer installations of equipment and wiring.

Wiring Provisions for 12-Volt Battery Power Supply (Tahoe)

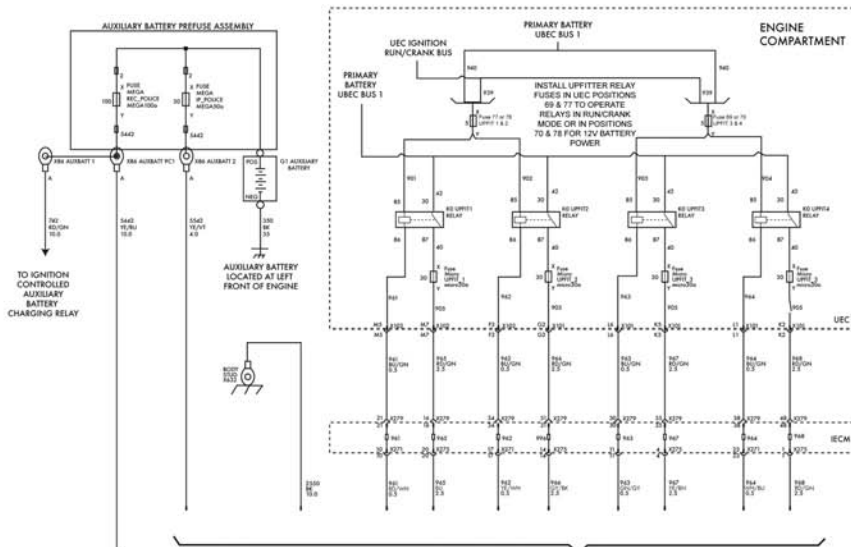

BLUNT CUT WIRING LOCATED BELOW CENTER OF INSTRUMENT PANEL

ELECTRICAL COMPONENT IDENTIFICATION:
 UEC-UNDERHOOD ELECTRICAL CENTER
 IECM-INTERMEDIATE ELECTRICAL CENTER-MIDDLE
 REC-REAR ELECTRICAL CENTER, LEFT REAR

Wiring Provisions – 12-Volt Battery Power – Tahoe

WIRING PROVISIONS IGNITION POWER AND SIGNAL CIRCUITS

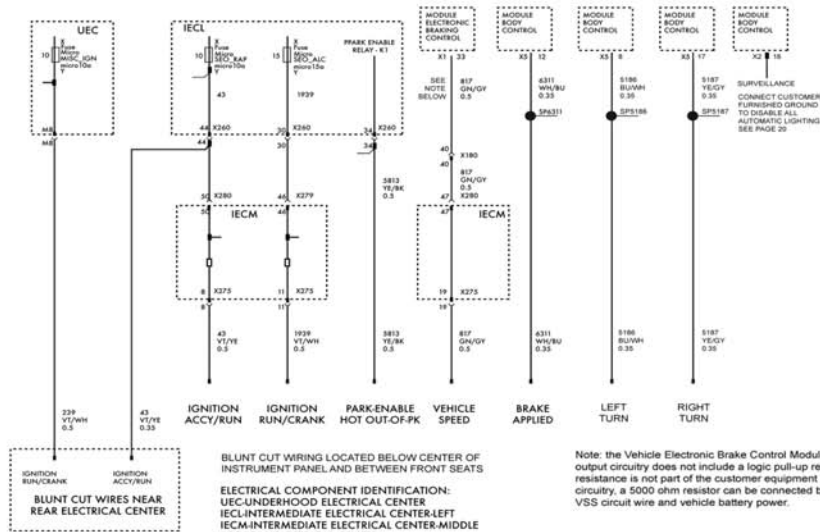

Wiring Provisions – Ignition Power and Signal Circuits – Tahoe

The vehicle is equipped with wiring provisions for connecting 12-volt battery power to customer installed equipment. Refer to the following information when adding electrical accessories that will use the 12-volt power supply circuits connected to the vehicle's electrical system. A wiring harness is below the instrument panel (IP) near the center of the vehicle and another connection point is in the left rear of the cargo area. The following information provides wiring diagrams and operation descriptions to aid in connecting customer equipment.

Electrical Connections

Caution

Before modifying or adding any wiring, be sure that it will work properly with your vehicle's wiring system. Because there are so many modifications that can be made for many different bodies and accessories, GM cannot take

(Continued)

Caution (Continued)

responsibility for any changes made. Such changes may not be covered by your GM Warranty. Have the work done by an experienced electrical technician.

All wiring must be properly protected by fuses, etc. and must be routed properly so that it will not be cut, pinched, or rubbed by other parts of the vehicle. Do not route wiring in areas where it will be very hot. Be sure not to overload the vehicle's wiring, connectors and components. All added wire must be at least the same size as the wire being attached to for proper fuse protection.

Installation Instructions – 12-Volt Accessory Power Supply

1. Disconnect the negative (-) battery cable at the battery. The negative (-) battery cable must be disconnected before

the positive wiring lead is connected to the power accessory.

2. Locate the power supply harnesses: one under the instrument panel near the center of the vehicle, and one within the driver side rear cargo area jack stowage compartment.
3. Prepare the wires that are to be used to connect the power accessory. Do not remove the unused wires. Tape unused wires back in their original position under the instrument panel.
4. Complete the wiring installation of the customer-added accessory with additional wire required for the specific electrical accessory power connection. The wire gauge, 3.0 mm² (12 gauge), should be the same as the wiring of the installed harness.

- The ignition must be turned to OFF prior to attaching the cables to the battery, or serious damage to the Body Control Module (BCM) may result.

The windshield wiper switch and the radio must be turned off before attaching cables to the battery.

- Reconnect the negative (-) battery cable to the battery. Torque the bolt to 5 N•m (3.6 lb ft).
- Reset the clock time and radio pushbuttons as desired.

Auxiliary Power System - Tahoe Police and Special Service

The 12-volt battery power for customer connection is supplied from the primary vehicle battery through control relays to four blunt cut 30 amp circuit wires and from an auxiliary battery through one blunt cut 50 amp circuit wire in the harness under the center IP. A 100 amp Rear Electrical Center

(REC) stud is in the left rear cargo area. A blunt cut ground wire is also included in the front harness.

The primary battery is at the right rear of the engine compartment and the auxiliary battery is at the left front of the engine compartment. The auxiliary battery is connected to the vehicle charging system through a relay which is closed when the ignition is ON.

Four 30 amp control relays and 30 amp fuses are in the underhood Electrical Center (UEC). Also in the UEC are two 5 amp fuses which connect control relay coils 1 and 2 and control relay coils 3 and 4 to the UEC primary battery power bus. The fuses can be re-positioned to connect the relays to the UEC primary battery Ignition Power (Run/Crank) bus. Refer to the UEC label showing the 5 amp fuse locations. The 5 amp fuse positions are labeled Vbat for the primary battery power and R/C for the Run/Crank power.

The 5 amp fuses can be positioned to have all four control relay coils powered by the primary bus or all four powered by the Run/Crank bus. Alternatively, one pair of relay coils (e.g., 1 & 2) can be connected to the primary bus and the other pair of relay coils (e.g., 3 & 4) connected to the Run/Crank bus.

The four control relays are operated through separate blunt-cut wires in the harness under the instrument panel and are intended to be connected through customer switching to vehicle ground. The auxiliary power control relay control wires and the relay contact 30 amp load side wires for customer connection are identified as follows:

Control Relay Ground control wires:

- Red/White: Control relay 1
- Yellow/White: Control relay 2
- Green/Gray: Control relay 3
- White/Blue: Control relay 4

12-volt, 30 amp load wires:

- Blue: Control relay 1
- Gray/Black: Control relay 2

- Yellow/Brown: Control relay 3
- Red/Green: Control relay 4

Blunt cut ignition control and signal wires are also in the harness under the center IP and between the front seats:

- A Violet/Yellow circuit wire, hot in ACCESSORY/RUN. This circuit is also provided in a coil in the cargo area near the REC.
- A Violet/White circuit wire, hot in RUN/CRANK. This circuit is also provided in a coil in the cargo area near the REC.
- A Yellow/Black circuit wire, transmission in P (Park) signal. The circuit provides switched 12-volt power when the shift lever is in Park and the engine is running. The circuit is at 0 volts when the shift lever is in any other position, (i.e., R, N, D, L). Note that the circuit is at 12 volts when the transmission is in P (Park) and the ignition is in LOCK/OFF. To avoid the possibility of undesired parasitic electrical load when the ignition

is off, it is recommended that the Park Signal circuit be isolated by a customer-furnished ignition control relay.

- A Green/Gray circuit wire for Vehicle Speed signal providing 4,000 pulses per mile. Some customer equipment may require a 5000 ohm pull-up resistance connected between the Green/Gray wire and battery 12 volts.
- A White/Blue circuit wire for 12 volts when the Service Brakes are applied.

Auxiliary Battery Power Junction Blocks

A 100 amp stud for customer connection is in the Rear Electrical Center (REC) at the left rear of the Tahoe cargo area.

To connect the customer-furnished equipment at the REC:

1. Disconnect the negative (-) battery cable.

2. Connect the customer-furnished equipment positive leads to the junction block terminals and tighten to 15 N·m (11 lb ft).

The ignition must be turned off and the vehicle vacated prior to connecting the negative (-) battery cable to the battery.

3. Reconnect the negative (-) battery cable to the battery. Torque the bolt to 5 N·m (3.6 lb ft).
4. Set the time on the clock and radio pushbuttons as needed. See "Introduction" in the Infotainment section of the owner manual.

Auxiliary Battery

The Tahoe and Silverado are equipped with an auxiliary battery. The Silverado does not have a wiring provision under the instrument panel for customer connection. Customer connection must be made at the auxiliary battery post Pre-fuse. Connection

harnesses are available from the GM Second Stage Manufacturer at 905-725-6561.

Radio Suppression Grounding Straps

Your Tahoe Police Package and Special Service Package are equipped with additional grounding straps in the following locations:

- Driver side front frame body mount bracket to underbody
- Driver side rear frame body mount bracket to rear underbody
- Passenger side rear frame body mount bracket to rear underbody
- Passenger side front frame body mount bracket to front underbody
- Exhaust pipe hanger rod to rear frame

SEO Available Options

Auxiliary Dome Lamp - SEO 6C7

The red and white auxiliary dome lamp is on the headliner between the driver and the front passenger seating positions. The switch for this lamp is at the rear base of the lamp. To operate the lamp, press the switch to one side for red light, and the other for white light. Position the switch in the center for OFF.

Exterior Lamp Emergency Flashing System - SEO 6J7 (Tahoe)

SEO 6J7 provides a high-beam headlamps flashing module, rear lamps flashing and control wire for a customer-furnished switch to turn the module on or off. The flasher control wire is coiled under the center of the instrument panel. This control lead may be combined with

the interior wiring leads for SEO 6J3 when that option is ordered with SEO 6J7.

The headlamps flashing module is below the passenger side front headlamp and forward of the passenger side front wheel. The module is connected to an inline connector in the forward lamp harness. The headlamps flashing module is activated by the application of 12 volts to a green wire coiled in the passenger side footwell. When activated, the driver and passenger side high-beam headlamps and the high-beam instrument cluster light will flash alternately at 2.4 flashes per second.

When the headlamps flashing module is turned on, the module sends a signal to the Body Control Module (BCM). The BCM alternately flashes the stop lamps and back-up lamps. Pressing the brake pedal will override the stop lamp flashing and placing the transmission in R (reverse) will override the back-up lamp flashing.

Activation of the headlamp and rear lamp flashing can be separated by opening the blue/green BCM circuit at the flasher module connector, X196-F, and applying a customer-switched ground to the blunt-cut wire in the SEO 6J3 connector under the center instrument panel.

During daylight conditions, the Daytime Running Lamps (DRL) are automatically turned off whenever the headlamps flasher module is activated. During nighttime conditions, the low-beam headlamps turn on automatically while the high-beam headlamps flash. Turning on the high-beam headlamps manually with the turn signal lever will override the flashing module and the high-beam headlamps will operate continuously.

A 10 amp fuse protects the flasher module circuit. This fuse is in the Underhood Electrical Center in the engine compartment on the driver side of the vehicle and is labeled POLICE UPFITTER. See “Engine Compartment Fuse Block” in the Vehicle Care section of the Tahoe owner manual.

When it is dark outside, the taillamps will turn on automatically. The Center High-Mounted Stoplamp (CHMSL) will not flash and will operate only when the regular brake pedal is pressed.

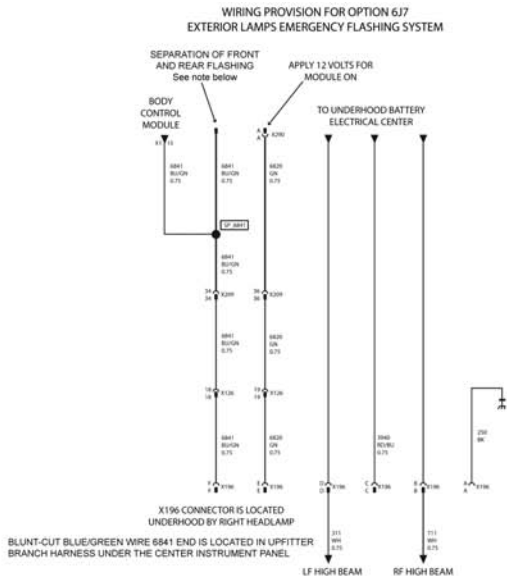

Forward Lamp Harness In-Line Connector for use with Headlamps Flasher Module, Option 6J7 – Tahoe

Exterior Lamp Emergency Flashing System - SEO 6J7 (Silverado)

SEO 6J7 provides a high beam headlamp flashing module, rear lamps flashing module and control wires coiled under the instrument panel for connection to customer-furnished switching to turn the modules on and off. The module control wires may be combined in a connector with the wires for SEO 6J3, Wiring Provisions for Vehicle Grille Lamps and Speaker/Siren, when that option is ordered.

The High Beam Headlamp Flashing Module is on the inboard sidewall of the Underhood Electrical Center (UEC) and the Rear Lamps Flashing Module is on the body dash panel to the rear of the UEC.

The Headlamp flashing module is activated by the application of 12 volts to a RED control wire coiled under the instrument panel. When activated, the driver and passenger side high beam headlamps and high

beam instrument cluster light will flash alternately at 2.4 flashes per second.

The rear lamps flashing module is activated by the application of 12 volts to a BROWN control wire coiled under the instrument panel. When activated, the rear stop lamps will flash alternately with the backup lamps.

Pressing the brake pedal will override the stop lamps flashing. Placing the transmission in Reverse will override the backup flashing and also cause the stop lamps to flash at a higher rate.

Activation of the headlamp and rear lamps flashing can be separated by connection of the RED and BROWN control wires to separate switching.

During daylight conditions, the Daytime Running Lamps (DRL) will remain on whenever the headlamps are flashing. During nighttime conditions, the low beams will turn on automatically while the high beam headlamps flash. Turning on the high beam headlamps manually with the turn signal/multifunction

lever will override the high beam flashing and the high beams will operate continuously.

The headlamps and rear lamps flashing modules are protected by 10 amp fuses in fuse holders near the flashing modules.

During nighttime conditions, the tail lamps and front position lamps come on automatically. The Center-Mounted Stop Lamp (CHMSL) will not flash and will operate only when the brake pedal is pressed.

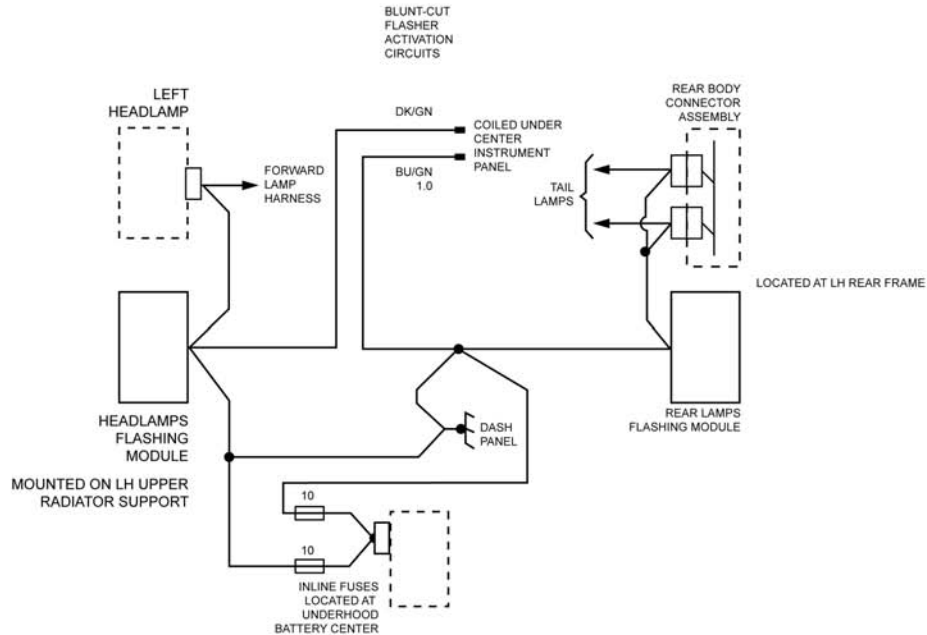

Forward Lamp Harness In-Line Connector for use with Headlamps Flasher Module, Option 6J7 – Silverado

**Rear Windows
Inoperative - SEO 6N5
(Tahoe)**

This feature makes the rear windows inoperative. The rear windows can only be operated from the driver window switch.

**Inoperative Rear Door
Locks and Handles - SEO
6N6 (Tahoe)**

This feature makes the rear door locks inoperative. When the feature is enabled, the rear door lock switches are inoperative and the rear doors can only be opened from the outside.

Spotlamp - SEO 7X6

Spotlamp – Windshield Pillar Mounted

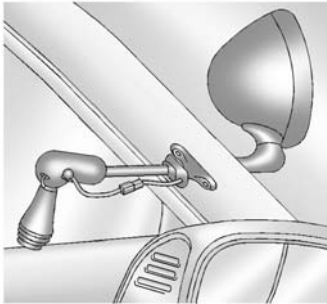

A Unity Series 330, high intensity, 100 watt halogen (H3 bulb) 15 cm (6 in) spotlamp is mounted in the left windshield pillar. The lamp is protected by a 15 amp fuse in the instrument panel Intermediate Electrical Center-Left. See the service manual for lamp replacement procedures.

WINDSHIELD PILLAR-MOUNTED SPOTLAMPS
OPTION 7X6 LH ONLY / OPTION 7X7 LH AND RH

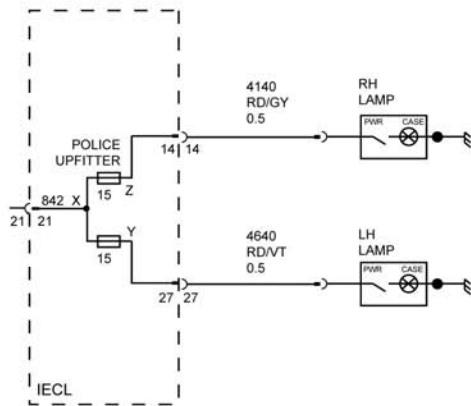

IECL - INTERMEDIATE ELECTRICAL CENTER-LEFT

LAMP BULBS - HALOGEN H7635

Spotlamp Harness – SEO 7X6, SEO 7X7 – Tahoe

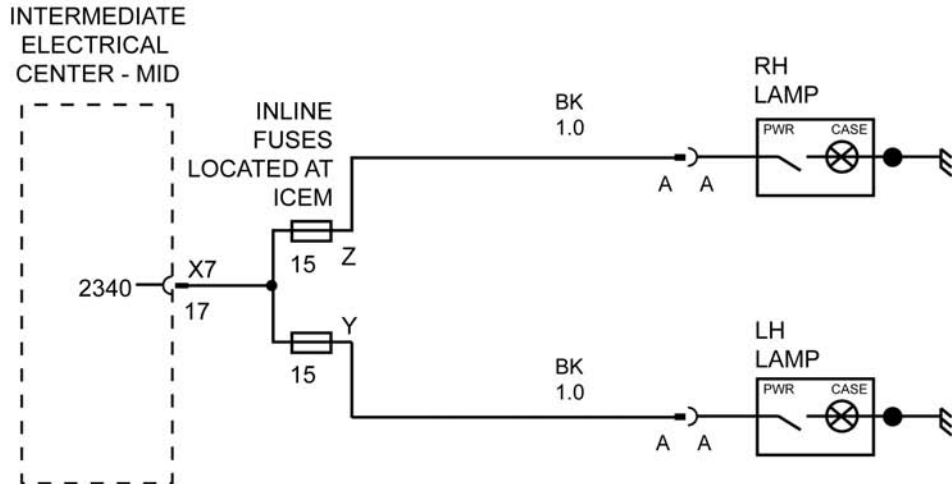

LAMP BULBS - HALOGEN H7635
 Spotlamp Harness – SEO 7X6, SEO 7X7 – Silverado

Spotlamps - SEO 7X7

SEO 7X7 includes a driver side and a passenger side spotlamp in the windshield pillars. Each spotlamp is protected by a separate 15 amp fuse in the Tahoe instrument panel Intermediate Electrical Center-Left. The Silverado spotlamp fuses are inline near the Intermediate Electrical Center-Mid.

For spotlamp bulb replacement procedures, see the service manual.

Wiring Provisions for Vehicle Grille Lamps and Speaker/Siren - SEO 6J3

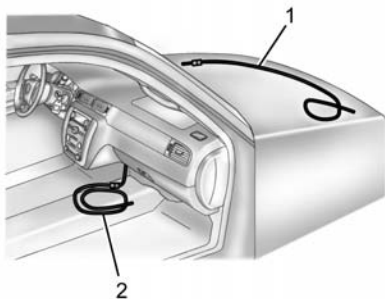

Alternating Signal Flasher

1. Control Wires from In-Line Connector in Forward Lamp Harness for Customer-Furnished Grille Lamps and Speaker
2. Blunt cut ends for the Customer-Furnished Grille Lamps and Customer-Furnished Siren/Speaker

The SEO 6J3 wiring provision option consists of a 1.5 m (5 ft) wiring harness coiled underneath the instrument panel on the passenger side. The wiring circuits are routed from underneath the instrument panel to a 30 cm (1 ft) coil secured in the area behind the grille. There are four 1.0 mm² (16 gauge) wires for connecting to the grille lights (gray/violet, yellow/green) and siren speaker (blue/green, green/yellow).

The SEO 6J3 wiring provision connector also includes a control wire (green) and an exterior lamps flashing system wire (blue/green) to permit separation of front lamp flashing from rear lamp flashing.

When option SEO 6J7 is installed on the Tahoe without option SEO 6J3, only the green and blue/green wires are provided for connection to customer-furnished 12-volt switching to turn the emergency flashing system on or off. See also SEO 6J7 for means of separating front and rear flashing.

WIRING PROVISION FOR OPTION 6J3 VEHICLE GRILLE LAMPS AND SPEAKER/SIREN

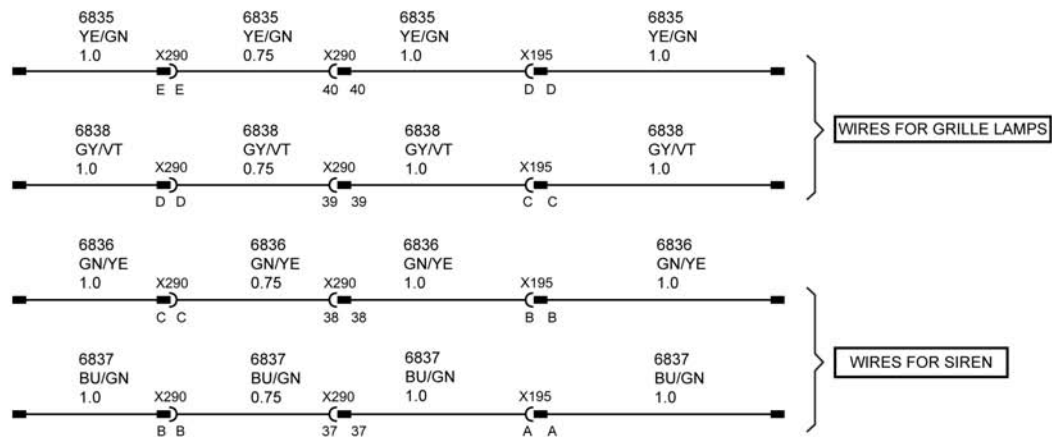

PACKAGED UNDERHOOD BY RIGHT REAR BATTERY
Wiring Diagram for SEO 6J3 – Tahoe

BLUNT-CUT ENDS
UNDER CENTER
INSTRUMENT PANEL

BLUNT-CUT ENDS
AT THE RIGHT SIDE
OF THE HOOD LATCH

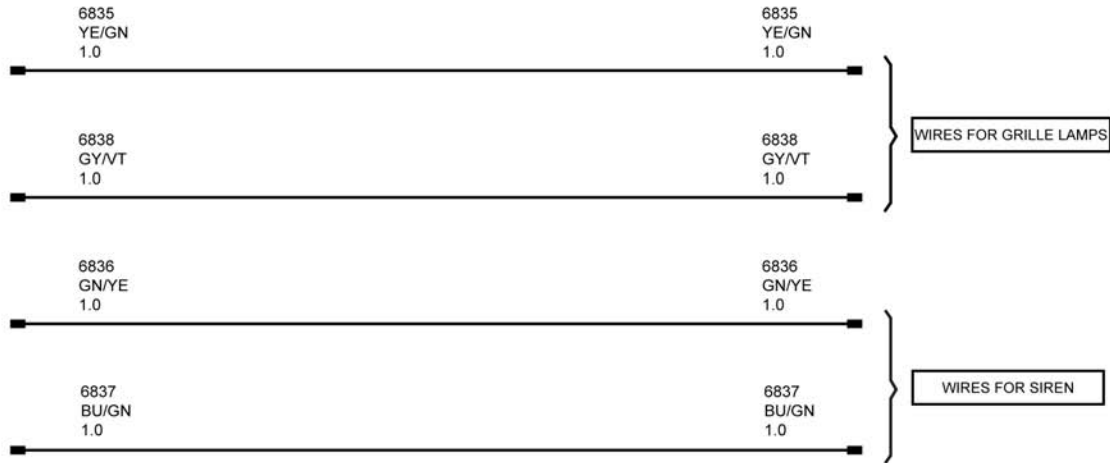

Wiring Diagram for SEO 6J3 – Silverado

Trunk Ground Stud - SEO UT7 (Tahoe)

The Tahoe Police or Special Service Package has grounding studs at the lower driver side and passenger side rear compartment liftgate opening for connection to customer electrical equipment.

Wiring Provisions for 12-Volt Battery Power Supply - SEO 9L7 (Silverado)

Power is supplied from the Silverado primary battery to the Intermediate Electrical Center - Middle (IECM) connector X7 under the instrument panel near the steering column. Four relay controlled 30-amp circuits are provided in the IECM connector for customer connection. A mating jumper harness for X7 is not provided. The mating connector part for customer assembly is available from a dealer or from the GM Second Stage Manufacturer (905-725-6561) as a jumper harness assembly.

58 Special Equipment Options

The four relays are operated from a switch bank in the center instrument panel. Refer to the wiring diagram for the following 30-amp load connections:

Switch Bank	X7 Terminal	Wire Color
1	20	Blue
2	14	Gray/Black
3	4	Yellow/Brown
4	1	Red/Green

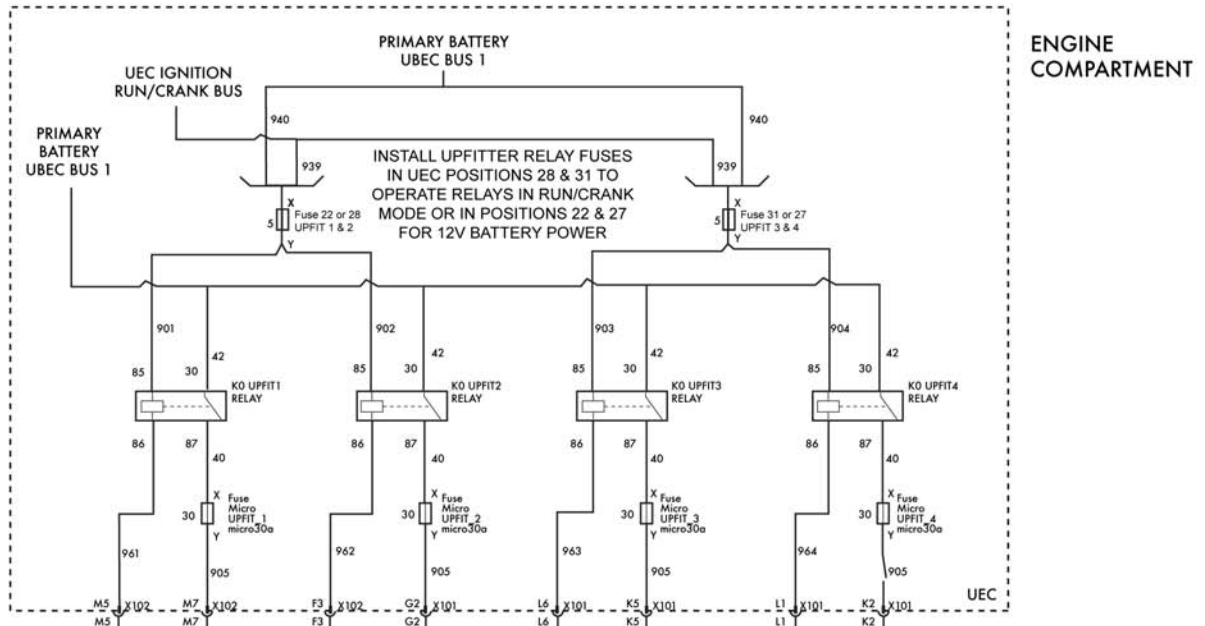

Wiring Provisions for 12-Volt Battery Power Supply - SEO 9L7 - Silverado (Part 1 of 2)

60 Special Equipment Options

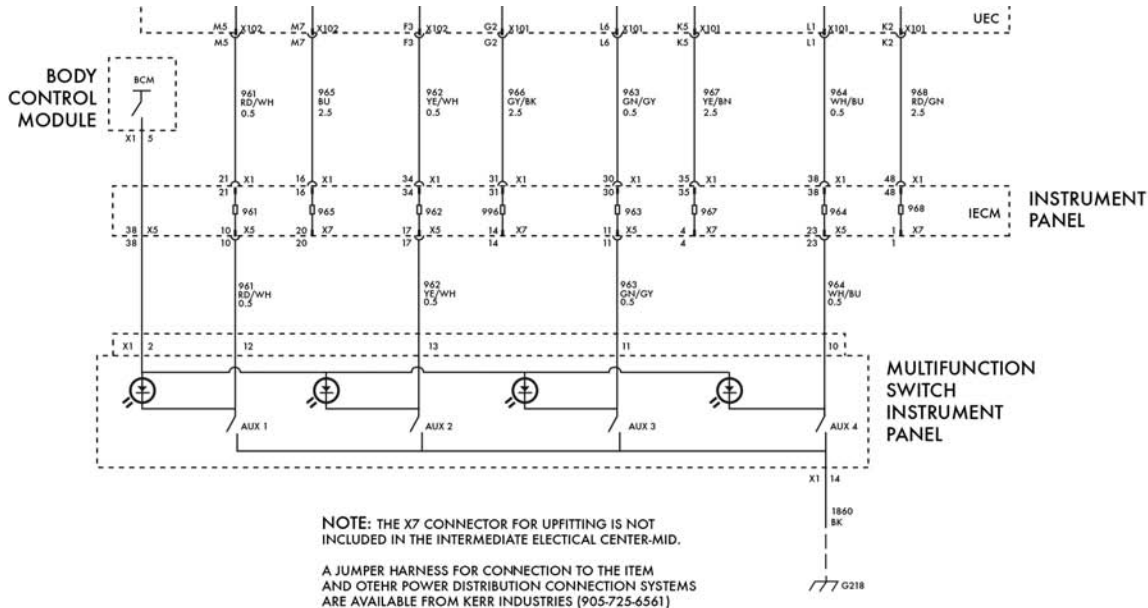

Wiring Provisions for 12-Volt Battery Power Supply - SEO 9L7 - Silverado (Part 2 of 2)

Wiring Provisions for Horn/Siren Circuit - SEO 6J4

This provision permits customer connection of a switch to select either horn or siren operation when the horn pad is pressed.

A 0.35 mm² (22 gauge) wire is connected to an in-line connector in the horn circuit of the instrument panel harness under the instrument panel. The end of this harness extension is in a 1.5 m (5 ft) loop of wire coiled under the center of the instrument panel.

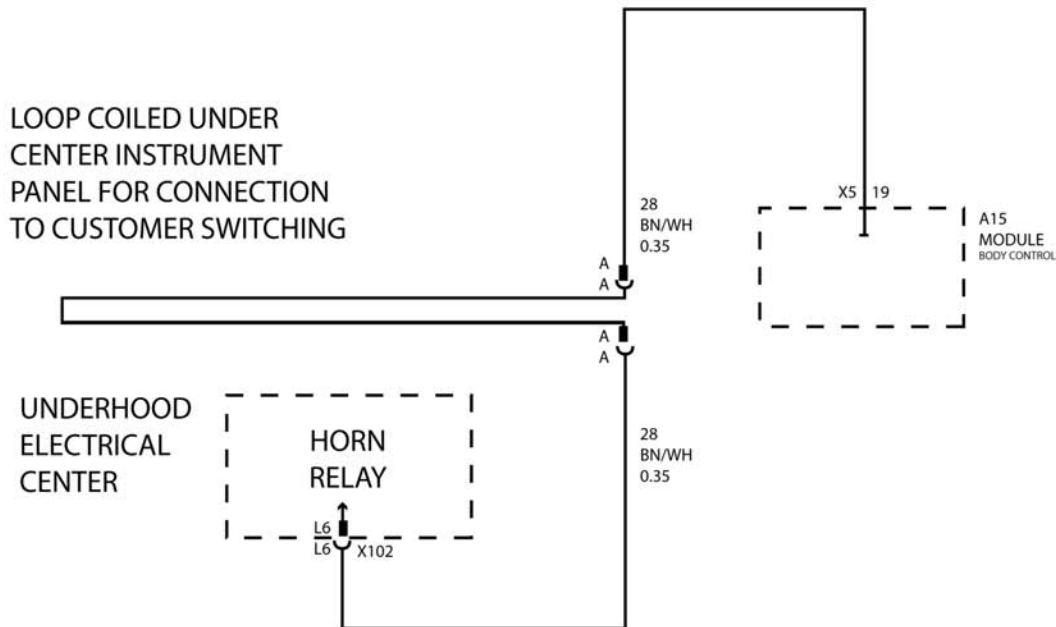

Wiring Diagram for SEO 6J4 Inline Connector

Wiring Provisions Front Speakers - SEO WX7 (Tahoe)

About 165 cm (65 in) of auxiliary speaker wire is run from the instrument panel radio connector and is coiled under the center of the instrument panel. The wiring permits the connection of front speakers to customer-installed communication equipment.

Radio outputs from the front speakers are sent to the rear speakers to maintain the required open door/key in the ignition reminder chime.

Electrical Connections

1. Disconnect the negative (-) battery cable at the battery.
2. Remove the tape from the wire coiled under the instrument panel to uncoil it.
3. Using proper electrical connectors, connect the wires for the left front audio output of the customer-installed communication device. The left front positive wire is tan and the left front negative wire is gray.
4. Using proper electrical connectors, connect the wires for the right front audio output of the customer-installed communication device. The right front positive wire is light green and the right front negative wire is dark green. The electrical impedance of each speaker installed is 10 ohms.
5. The ignition must be turned off and the vehicle must be vacated prior to attaching the cable to the battery. Connect the negative (-) battery cable to the battery and tighten the bolt to 5 N·m (3.7 lb ft).
6. Set the time on the clock and radio pushbuttons as needed. See "Introduction" in the Infotainment section of the owner manual.

Caution

Overloading the vehicle's electrical system may damage the vehicle's accessories. Do not overload the vehicle's system by having unnecessary accessories on at the same time.

WIRING PROVISION FOR OPTION WX7, FRONT SPEAKERS CONNECTION

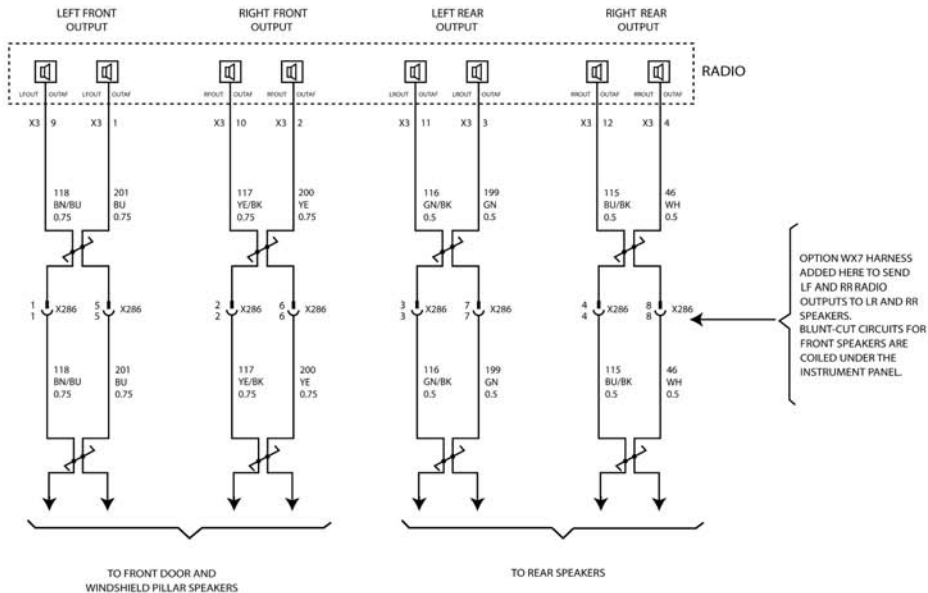

Wiring Diagram for SEO WX7 Inline Connector (Tahoe)

Index

A

Airbags	
Deployment Diagrams	10
Questions and Answers About Airbags and Specialty Law Enforcement Vehicles	7

Auxiliary

Available Option	44
Auxiliary Battery Power	
Junction Blocks, Available Option	44
Auxiliary Dome Lamp	
SEO - 6C7	45

B**Battery**

Power Junction Blocks	44
Wiring Provisions for 12-Volt Power Supply	40

C

Canadian Vehicle Owners	3
Capacities and Specifications	37
Circuit	
Wiring Provisions for Horn/ Siren - SEO 6J4	61
Cluster, Instrument	19, 21
Customer-Installed Equipment	8

D

Deployment Diagrams	10
Driver Information	
Center (DIC)	22
Driving	
Vehicle Load Limits	24

E

E85 or FlexFuel	28
Equipment	8
Exterior Lamp Controls	23
Exterior Lamp Emergency	
Flashing System - SEO 6J7	45, 48

F

Fast Idle System	27
Flasher, Wiring Provisions - SEO 6J3	54
FlexFuel	
E85	28
Floor Mats	35
Fuel	
Filling the Tank	28

G

Gauges	
Speedometer	22
Ground Stud, Trunk - SEO	
UT7, Available Option	57
Grounding Straps	
Radio Suppression	45

H

Horn/Siren, Wiring Provisions	
- SEO 6J4	61

I

Idle System	
Fast	27
Inoperative Rear Door Locks	
and Handles - SEO 6N6	50
Instrument Cluster	19, 21
Introduction	2

K

Keys	
Single Key Random Code	
System	5

L

Lamp	
Auxiliary Dome, SEO - 6C7	45
Lamps	
Exterior Controls	23

Lamps (cont'd)

Exterior Emergency	
Flashing System -	
SEO 6J7	45, 48
Vehicle Grille Wiring	
Provisions - SEO 6J3	54

M

Monitor System, Tire Pressure ...	34
-----------------------------------	----

P

Police Package and Special	
Service Package, SEO	
Standard Options	39

Q

Questions and Answers About	
Airbags and Specialty Law	
Enforcement Vehicles	7

R

Radio Suppression Grounding	
Straps	45
Rear Door Locks and Handles -	
SEO 6N6	
Inoperative	50
Rear Windows Inoperative -	
SEO 6N5	50

S

Safety Belts	
Questions and Answers About	
Airbags and Specialty Law	
Enforcement Vehicles	7
SEO Standard Options	
Police Package and Special	
Service Package	39
Speaker/Siren, Wiring	
Provisions - SEO 6J3	54
Speakers	
Wiring Provisions, Front -	
SEO WX7	63
Specific Cylinder Unit for Single	
Key - Random Code System	5
Specifications and Capacities	37
Speedometer	22
Spotlamp	
SEO 7X6	51
Spotlamps	
SEO 7X7, Available Option	54
Supplement	
Using	3

T

Tires	34
Pressure Monitor System	34
Towing	
Trailer	29
Trailer	
Towing	29
Trunk Ground Stud - SEO	
UT7, Available Option	57

U

Using This Supplement	3
-----------------------------	---

V

Vehicle	
Canadian Owners	3
Load Limits	24

W

Wiring Provisions	
12-Volt Battery Power	
Supply	40
12-Volt Battery Power	
Supply - SEO 9L7	57
Front Speakers - SEO WX7	63
Horn/Siren Circuit - SEO 6J4 ...	61
Vehicle Grille Lamps, and	
Speaker/Siren - SEO 6J3	54
Wiring Provisions for 12-Volt	
Battery Power Supply -	
SEO 9L7	57